

Turbo charger Telemetry dynamic strain gage, thermocouple type K

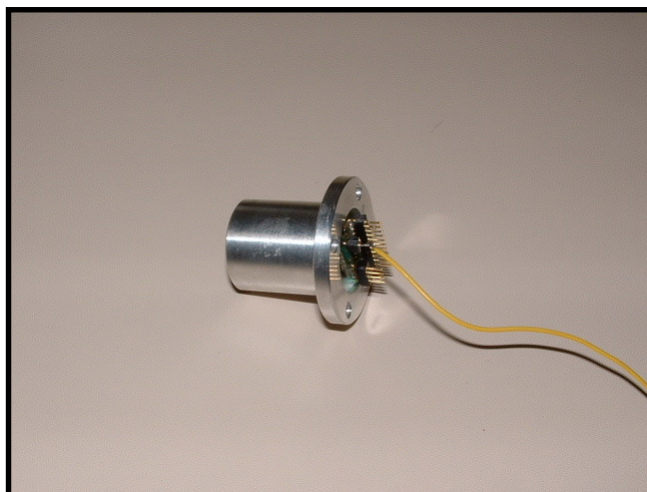
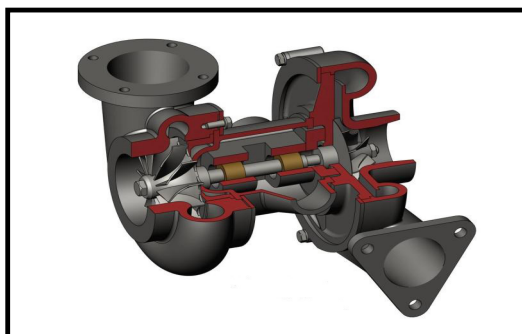

Small Transmitter
Cylinder 30mm x 8 mm

The ATCOM TELEMETRY systems have especially been designed to achieve measurement and data transmission on motion machine parts.

<i>Real time measurement</i>	6 channels Temperature, 2channels Strength
<i>Sensor</i>	Type I,J,K,N thermocouple Strain gauge (1/4 , 1/2, full bridge)
<i>Operating condition</i>	-30/+125 °C (+135° optional) IP65 40 000g all directions
<i>Signal Bandwith per channel</i>	10 000 Hz (40000Hz optional)
<i>Resolution</i>	12 bits
<i>Receiver Outuputs</i> - Digital - Analog	USB/RS323/RS425 -5/+5Volts, 0-10V
Mecanical - Dimension - Casing	Weight 15g 25mm length, 8mm diameter Aluminum/Epoxy
Radio	Digital PCM-FSK Line of sight distance : 20mm